

Fig. 8: 122 GHz transceiver module, RF PCB circuit diagram

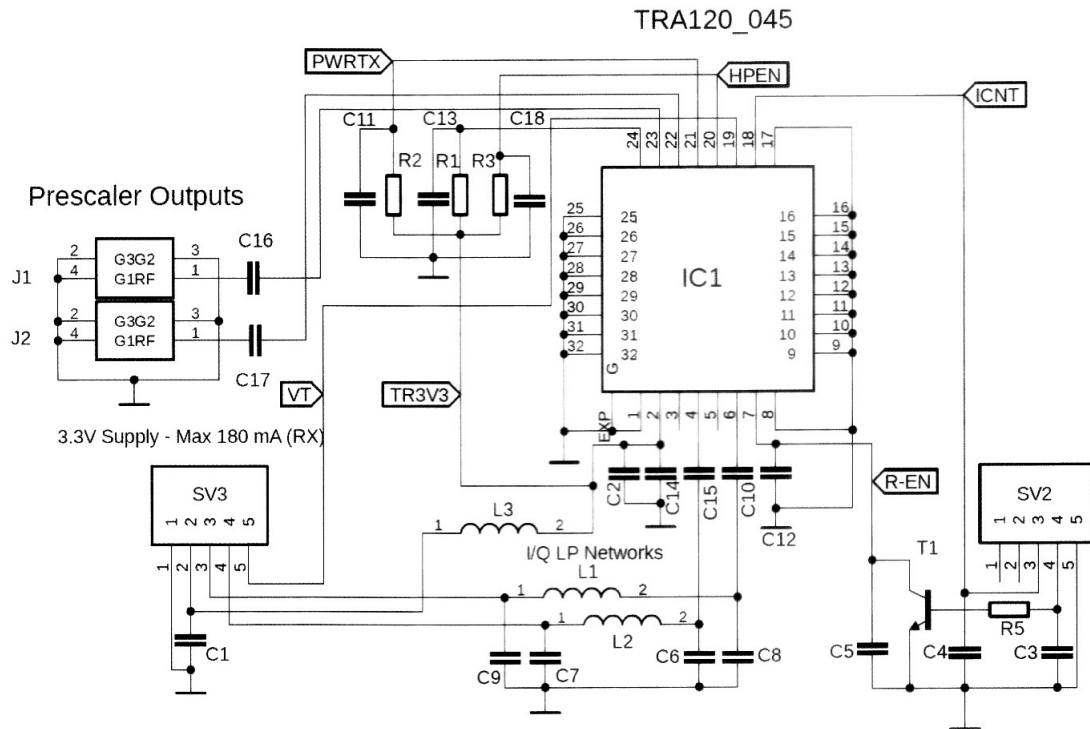

Fig. 9: 122/134 GHz transceiver module, RF PCB circuit diagram